



Estilo Series Nightstand

ES 4000-17

Max-Secure's research and development team has decades of experience solving issues specific to the corrections and institutional furniture industries. We have leveraged this experience to design a nightstand that is safe, secure, durable and styled to meet current furniture trends.

For 40 years, Max-Secure furniture has been installed in correctional facilities across North America with a "zero failure" record when installed by our specialized team. Constructed with Max-Secure's advanced polymer composition, our nightstand exceeds all national and state fire codes and impact load tests. The rotationally molded process used in manufacturing the nightstand inherently creates a strong, durable and stable base. The rounded corners ensure safety and reduce the possibility of injury. The nightstand is available in a variety of contemporary colors to compliment your facility's decor.

MAINTENANCE FREE FABRICATIONS

Max-Secure furniture is maintenance-free and comes with a standard industry five-year warranty. Our nightstands are designed to make your resident rooms feel more like living areas and are proven to withstand continuous use in institutional and correctional environments.

PROPRIETARY ADVANCED POLYMER MATERIAL

All Estilo Series products are constructed from our proprietary advanced polymer composition. This proven material has been formulated to be maintenance-free, impact resistant, and will not produce toxic fumes.

See back for details.

PRODUCT FEATURES

- Five-year limited replacement warranty
- Maintenance-free monolithic construction
- Designed to prevent injury to self or others
- Meets all national and state fire codes
- Advanced Polymer composition will not produce toxic fumes
- No exposed fasteners
- No space for concealment
- Installed with a secure structural mounting system with optional perimeter pick-proof sealant

MAX-SECURE™

Institutional Furniture

Estilo Series Nightstand

ES 4000-17



Nightstand ES 4000-17 Shown with Herculite Bed EN 6000-1

STANDARD PRODUCT COLORS



C132
Pewter
Grey

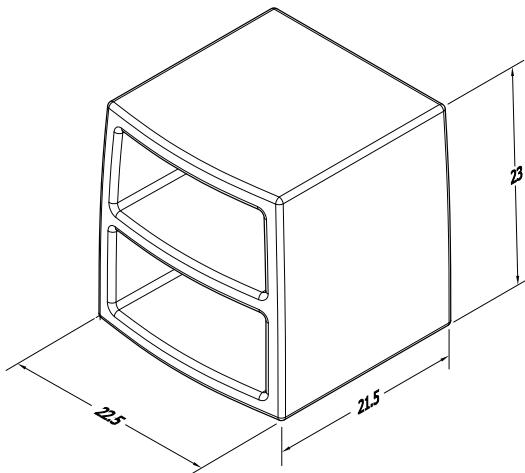

MaxSecure Systems Inc.

300 International Drive, Suite 100
Williamsville, NY 14221
USA

Phone: (800) 657-4336
Fax: (800) 769-4463
max-secure.com



Distributor

PERFORMANCE TESTING

ANSI/BIFMA X5.1 2011 General Purpose Office Chairs Compliance for Static and Dynamic Load

Chemically Resistant to Various Chemical Reagents

UV Stabilized

FLAMMABILITY COMPLIANCE

California No. 133 Flammability Test Procedure For Seating Furniture

UL94 Standard for Safety of Flammability of Plastic Materials

PRODUCT WEIGHT

12 KG / 25 Lbs.

RELATED PRODUCTS

Herculite Bed [EN 6000-1]

Two Shelf Locker [EN 6000-7]

Four Shelf Locker [EN 6000-8]

Utility Shelf [EN 6000-23]

WARRANTY

Five-year limited replacement warranty.

MASTER FORMAT NUMBERING (FILING SYSTEM)

11 19 70 Correctional Furniture

12 60 00 Institutional Furniture

INSTALLATION

Freestanding or secure in place with a structural mounting system with optional perimeter pick-proof sealant. Call for a quotation for complete installation from our factory-trained technicians.

ACCESSORIES

Ballasting bags (dry sand provided by others)

Structural Mounting System

OPTIONAL COLORS (NON-STOCKED)

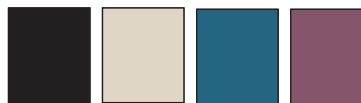

C130
Onyx
Black

C131
Sandstone

C134
Poseidon

C135
Marsala

